

Cerro Gordo County Planning & Zoning Staff Report

SPECIAL USE

Case No.: 19-25	Date of Application: March 5, 2019
Use Request: 20.2(Q) Travel Trailer Park	Owner: William Dewey
Current Zoning: A-2 Agricultural	Petitioner: William Dewey
Address: 11091 210 th Street Rockwell, IA 50469	Size of Special Use: 7.11 acres
Legal: NW ¹ / ₄ / NW ¹ / ₄ , Section 11, Mount Vernon Twp.	Size of Parcel: 7.11 acres
	Hearing Date: March 26, 2019

BACKGROUND INFORMATION:

1) PURPOSE OF SPECIAL USE REQUEST -

William Dewey (Dewey) is requesting a Special Use Permit to establish a 17-lot travel trailer park, including a personal space for operations, on property he owns at the corner of 210th Street (County Road B-43) and Killdeer Avenue. The travel trailer park would be open to the public. The land currently has an existing building site on the east half and is in agricultural production on the west half (See Figures 1-3). There is an existing utility building and well house on the building site (See Figure 4 & 5).

The proposed park includes a pond near the northwest corner of the property (See Figure 6). A majority of the travel trailer spaces will be located on the west half of the property in a loop configuration (See Figure 3). Three large pull-through spaces will be located on the east half of the site, southwest of the existing utility building (See Figure 7). Between the pull-through spaces will be a community building with a game room, laundry, and bathroom and shower facilities (See Figure 7). Dewey will have a personal travel trailer space and office building along the west side of the east driveway (See Figure 8).

2) EXISTING LAND USE AND ZONING CLASSIFICATION OF PROPERTY –

The land currently has an existing building site on the east half and is in agricultural production on the west half (See Figures 1-3). There is an existing utility building and well house on the building site (See Figure 4 & 5). The property is zoned A-2 Agricultural.

3) LAND USE AND ZONING CLASSIFICATION OF SURROUNDING PROPERTY -

The majority of the surrounding land is in agricultural production and zoned A-1 Agricultural. There is a commercial grain operation owned by A & K Feed & Grain Co., Inc. to the northwest, which also includes a residence (See Figure 9).

There are two additional rural residences about a half-mile of the site. There is a residence to the west owned by April Sherwood. The second residence is to the southeast, owned by Curtis and Holly Elvrumm.

GENERAL FINDINGS:

1) HARMONY AND ACCORD WITH GENERAL PRINCIPLES AND PROPOSALS OF ZONING ORDINANCE -

The intent of the Zoning Ordinance is to provide for the public health, safety, morals, comfort, and general welfare; conserve property values and encourage the most appropriate use of land; provide for the orderly

planned use of land resources; and facilitate adequate and economical provisions for public improvements.

Compliance with Health Department requirements can be ensured by requiring that a Zoning Permit is applied for prior to any construction. The use should not have an impact on morals, comfort, or general welfare. The proposed use does not run contrary to the orderly planned use of land resources. Finally, no additional public improvements should be required to serve this property.

Travel trailer parks like the one proposed are allowed in A-2 districts subject to a Special Use Permit being approved by the Board of Adjustment.

2) COMPATIBILITY OF USE WITH APPEARANCE AND ESSENTIAL CHARACTER OF AREA -

The character of the area is primarily agricultural and rural residential. The use will not involve tall structures or other features that would create a visual blight for nearby property owners. The property is mainly surrounded by farm fields—the nearest residence being about 850 feet to the northwest (See Figure 9). With only 17 campsites, the campground use will not be as intense as parks near the south shore of the lake.

The use be fairly apparent for drivers passing by but not much from a distance. Visual impacts can be controlled by requiring fencing or vegetative screening if the Board feels necessarily, particularly along road right-of-way around the west half of the property (See Figure 3, 6, & 10-11). However, requirements for fencing and visual clearance at the intersection of 210th Street (County Road B-43) and Killdeer Avenue. Dewey proposes an 8-foot tall, unclimbable chain-link fence around the perimeter of the property. This is probably a good compromise between these competing goals. The ordinance requirements emphasize visual screening, which is less of a concern due to the relative isolation of the location. Requiring some extra vegetative plantings on the along the right-of-way along road right-of-way lines on the inside of the fence away from the intersection would also aid toward this goal. There is also a road culvert running under 210th Street, which will be discussed below.

3) IMPACT ON EXISTING AND FUTURE USES, VICINITY, AND COMMUNITY AS A WHOLE -

Impacts on the vicinity include increased traffic, noise from people camping on the property, and smoke from cooking and recreational fires. These are discussed in more detail below.

4) ADEQUACY OF PUBLIC SERVICES (i.e., highways, streets, police, fire protection, drainage structures, refuse disposal, water and sewage facilities, or schools) -

Access to the site will be primarily from 210th Street (County Road B-43), which is paved. However, the site can also be accessed from Killdeer Avenue, which is graveled, though the driveway is proposed to be gated to limit access.

Law enforcement protection is provided by the Cerro Gordo County Sheriff's Department. Fire protection is provided by the Swaledale Fire Department. Emergency medical response is provided by both the Swaledale/Rockwell Fire Department EMTs and the Mason City Fire Department. There may be a slight increase for the demand of services simply due to the visitors the park has the potential to attract. The location is on a main county road, which behooves potential response times.

There is a road culvert running under 210th Street about 50 feet east of the nearby intersection (See Figure 12). The County Engineer states that no water flow should be obstructed from the culvert so that no additional flow arises from the special use to the culvert. If approved, this should be made a condition of the permit.

The site plan does not show locations for security lights or dumpsters. These should be required as a condition of approval.

The site is not within a floodplain; however, it is located within Drainage District 45. Dewey proposes to install a pond in the northwest corner of the site (See Figure 6). As a part of the installation, Dewey proposes to replace the existing drainage tile running through his property with new tile of equal or greater size. All of the tile will drain to the pond. The County Auditor and Board of Supervisors manage drainage districts within the county. The

County Auditor has provided comment that any repair or replacement of a public drainage tile requires approval by the Board of Supervisors, and possibly a certain threshold of property owners within the drainage district. Dewey will be required to make a request/apply through the Auditor's Office, including a hydrological study by a licensed drainage engineer showing that there is a need for repair or that the replacement of tile will be an improvement to the infrastructure. All required approvals for such improvements should be a condition of the permit. All costs should be at the expense of the applicant.

There is an existing well onsite (See Figure 5). Since over 25 people may be served by the water system, it is likely considered public by the DNR. The DNR will require that the well be tested regularly and will impact what is required for wastewater treatment. It is possible a new well may also be needed to be drilled, so a well permit may be required by the Health Department.

Bathrooms are proposed to be located in the community building on the southeast portion of the site (See Figure 2). Additionally, there will be a dump station and two holding tanks just to the northeast of the community building. Dewey proposes a leech field to be located in the southeast corner of the site (See Figure 13). The location of the leech field or septic system will be directly impacted by whether the well is considered a public water supply. The local DNR field office and Health Department have been asked to provide comment. All comments received will be share with the Board. A condition of the permit, if approved, should be that Dewey must receive all required permits from the DNR or Health Department. Also, a condition of the permit, if approved, should be that wastewater be removed by a method approved by the Cerro Gordo County Department of Public Health.

The use will not have an impact on schools.

5) PUBLIC COST FOR ADDITIONAL PUBLIC FACILITIES AND SERVICES -

It is unlikely that there will be any cost to the public for additional public facilities or services except as discussed above in regard to Drainage District 45. Dewey proposes to incur all costs for improvements to the public drainage tile, which should be a part of any conditions approved.

6) POTENTIAL DETRIMENTS TO PERSONS, PROPERTY, OR GENERAL WELFARE (i.e., excessive traffic, noise, smoke, fumes, glare, or odors) -

It is anticipated that the campground would be used between April and November each year, although this is not specifically stated in the narrative. Traffic counts from 2017 show an average of 530 vehicles per day in the 1 mile stretch of 210th Street running by the site. The section of Killdeer Avenue south of the county road only receives 20 vehicles per day. Based on the site plan, the campground will accommodate 17 travel trailers. This may add another 25-32 trips per day, especially on weekends and summer holidays.

Such an increase will be noticeable, but being a paved road, 210th Street is capable of handling the increase in traffic. Users of the site are highly unlikely to use Killdeer Avenue to access the site, as the west driveway will be gated and the primary access will be from 210th Street. Slowing traffic entering and leaving the site is somewhat of a concern. There is no turning lane on 210th Street. The County Engineer recommends the installation of warning signs for turning traffic going both directions on 210th Street. This should be a condition of the permit at Dewey's expense, if approved.

Noise from persons camping is also a possibility. The nearest residence is 850 feet to the northwest. The distance from the site should help mitigate any noise, but the Board would be justified in requiring the installation of a vegetative plantings along 210th Street if it feels necessary, while keeping in mind the intersection and drainage from the road culvert running under 210th Street.

Smoke carrying from cooking and recreational fires is unlikely to become a nuisance due to the distance of the closest residences.

There may be dust created by traffic on interior roads accessing campsites, which is also unlikely to become a nuisance either. The trees on the site will absorb some dust if much is created. It does not seem necessary to

require dust control onsite at this time, but the Board could require it if it feels necessary. The Board would have the option to revisit this issue if dust ever becomes a nuisance.

No fumes or glare will be created by the proposed use.

7) COMPATIBILITY AND CONSISTENCY WITH THE INTENT AND PURPOSE OF THE ZONING DISTRICT -

The A-1 district Declaration of Intent states that, "The A-2 Agricultural District is intended to serve the agricultural community and guide urban land use development in the rural area. It does allow for a limited number of agricultural service-related businesses." The special use will take approximately 3.5 acres of farmland out of production. The use is permitted in the A-2 District with a Special Use Permit by the Board of Adjustment under the ordinance. While not an agriculturally related use, travel trailer parks are a use that take large tracts of land to accommodate that are incompatible with densely populated areas. The location is appropriate to the goals of the district as a result.

8) COMPATIBILITY WITH COUNTY COMPREHENSIVE PLAN -

The objectives and policies of the county's Comprehensive Plan that pertain to this type of use can be summarized as follows:

- Non-farm uses should be limited to areas of poor or marginal soil in order to preserve productive soil.
- Non-farm development should be placed where it will be least disruptive to and will not hinder agricultural operations.
- Non-farm uses should be designed to blend in with the natural character of the land.
- Agricultural areas with a CSR of 70 or above should be preserved.
- Environmentally sensitive areas should be set aside and protected from development to prevent degradation.

The proposed use appears to meet some, but not all, of the above objectives and policy statements. The land in agricultural production has an average CSR of about 84 and is considered highly productive soil. However, if Dewey can improve the drainage of the area with large drainage tile flowing to the proposed pond (See Figure 6), he will likely be able to offset the loss in farmland somewhat and have a positive impact on areas of surrounding farmland that routinely floods each season, making those portions unfeasible to farm—particularly to the south (See Figure 14.). The special use will not impact agricultural operations away from the site otherwise.

Since the site is surrounded by farm fields and open areas, the location is virtually impossible to blend into the natural environment. Requiring vegetative plantings along the travelled roads can mitigate some of the visual impact of the special use, but the above discussed issues in regard to the intersection and road culvert must also be kept in mind. Also, the location is not within or near an environmentally sensitive area.

COMPLIANCE WITH ADDITIONAL ARTICLE 20 REQUIREMENTS:

Additional requirements for the special use requested are as follows. Ordinance requirements are in normal type. Comments are in **bold**.

20.2 SPECIAL USES

Q. Travel Trailer Parks. Any District except M-1 and M-2. **The property is zoned A-2 Agricultural.**

1. Minimum Requirements for Park:

- a. Front Yard. Same as district or fifty (50) feet, whichever is greater. This requirement shall apply to any and all roads or streets upon which "park" abuts. **By definition, Killdeer Avenue is considered the front of the lot because it is the narrow side of the corner lot. Proposed Lot 13 is 15.2 feet from the right-of-way of Killdeer Avenue. A variance would be necessary to permit the lot, though the Board would be justified to enforce the requirement. There does not seem to be a compelling reason to grant this variance request, so I would recommend that the Board enforces the rule. This should not significantly impact the proposed special use, as there is plenty of space to adjust the space's location.**
- b. Side Yard. Thirty-five (35) feet. **All lots are at least 35 feet from the north side lot line. The closest lots are about 30 feet from the south side lot line. There is an efficient use of space along the**

south side property line, and there is only a farm field on the property to the south, so a variance is not concerning for the south side yard setback.

- c. Rear Yard. Thirty-five (35) feet. **All lots are over 35 feet from the rear lot line.**
 - d. Minimum Area. One and one-half (1½) acres. **The site is approximately 7.11 acres in size.**
 - e. Maximum Density. Twenty (20) unit spaces per gross acre of park site. **The ratio is 2.4 spaces per gross acre.**
 - f. Drives. Twenty-five feet in width with asphaltic concrete surface. **Although not addressed by the application, the applicant is requesting a variance from this requirement. He would prefer to have gravel drives. The proposed interior drives will be 20 feet in width, with all curves being at least 25 feet in width. All drives are designed to have one-way traffic, so this request is not concerning.**
 - g. A Common Service Building providing laundry facilities, short order food service, accessory supplies, etc., may be included in the “park” permitted in the A-1 and A-2 Districts, provided such building shall not be visible to passing traffic; and shall be restricted to the use of the park occupants. Such service buildings shall be permitted in the C-2 District providing such use shall conform to the requirements provided in the C-2 District Regulations. **The property is zoned A-2. A community building with a game room, showers, a laundry, and bathrooms is proposed (See Figure 2). This meets the requirements of the C-2 District.**
 - h. The Rear and/or Side Yards shall be screened from adjacent property’s visual access by planting screen not less than ten (10) feet in width, or by an un-climbable fence wall in accordance with Article 19. **Article 19 requires a fence wall be a minimum of 6 feet in height constructed of “permanent, low-maintenance materials” or a weather resistant alternative. Dewey proposes an 8-foot tall chain link fence around the perimeter of the property. A solid fence wall would likely obstruct water flow in relation to the road culvert under 210th Street (See Figure 12). In that way, a chain link fence is preferable to allow the flow of water to the pond (See Figure 6). The biggest potential concern is the screening of the special use. I would recommend allowing the chain link fence as a means to allow for the water flow from the culvert while using a method such as requiring some vegetative plantings along right-of-way lines to help screen the use as much as possible.**
2. Requirements of “Travel Trailer” Spaces:
 - a. Minimum Space Size. Twenty (20) feet by fifty-five (55) feet. **The site plan shows that all 17 lots exceed this requirement.**
 - b. Minimum Space Area. One thousand one hundred (1,100) square feet. **The site plan shows that each space will meet this requirement.**
 - c. Off-Drive Parking. One (1) parking space for and within the area of each “Travel Trailer” space. **No parking is shown on the site plan, but Lots, 1-6, 9-12, 15, and 16 are all large enough to accommodate a parking space.**
 - d. Minimum Front Yard. Ten (10) feet. **This area must be accommodated within each site. Given the depths of the lots, most lots meet this requirement. However, there is not enough space for Lots 7, 13, and 14 to meet this requirement. All spaces have angled parking, making maneuverability though the campground much easier. Granting a variance for the front yard of the three spaces is reasonable.**
 - e. Minimum Rear Yard. Five (5) feet. **All lots meet this requirement.**
 - f. Minimum Side Yard. Five (5) feet. **All lots meet this requirement.**
 - g. Travel Trailer Separation. The minimum distance between any two (2) travel trailers shall be not less than then (10) feet. **All lots meet this requirement.**
 3. Site Plan Requirements:
 - a. A site plan of the park site shall be required for review and consideration of a “Special Use” permit. The site plan shall be prepared at a scale of not less than 1”=100’. **The site plan was drawn at a scale of 1”=30’ and meets this requirement.**
 - b. All provisions to meet the requirements of this Ordinance shall be clearly illustrated. **The site plan accomplishes this.**
 - c. All existing drainage and public utility facilities shall be shown; and proposed methods of storm water removal, waste removal and water distribution shall be stated on the plan. Detailed requirements shall be approved by the appropriate county department prior to the issuance of a special permit. **The site plan accomplishes this.**

- d. Final Travel Trailer Park development shall be in accordance with the approved site plan. **This should be made a condition of the Special Use Permit, if approved.**
4. Storage of Travel Trailers:
- a. Unoccupied mobile homes, travel trailers, campers, converted buses, motor homes, tent trailers or similar devices may be located in travel trailer parks for storage purposes as per the following:
 - b. A specific area must be designated as a storage area and all vehicles shall be located in this area during such time as the use is for storage.
 - c. The site plan shall identify the sites for occupied use and sites for storage.
 - d. Nothing in this article shall be construed to permit the repair, maintenance, sales or servicing of vehicles located in a travel trailer park. **Sites for the storage of travel trailers, etc. have not been designated on the site plan. Therefore, a condition of the Special Use Permit, if approved, should prohibit the ongoing storage of unoccupied mobile homes, travel trailers, campers, converted buses, motor homes, tent trailers, or similar devices.**

ZONING DISTRICT REQUIREMENTS:

Requirements of the zoning district for which the proposed special use is to be located are as follows. Ordinance requirements are in normal type. Comments are in **bold**.

- Minimum parcel size is 2 acres. **The site area is 7.11 acres in size owned by Dewey**
- 8.5 Height Regulations. No building hereafter erected or structurally altered shall exceed two and one-half (2 ½) stories or thirty-five (35) feet. **All proposed structures are less than 35 feet tall.**
- 8.6 Yard Requirements. Each lot shall have front, side and rear yards not less than the depths or widths following:
 - A. Front yard depth, fifty (50) feet.
 - B. Each side yard width, twenty-five (25) feet.
 - C. Rear yard depth, thirty (30) feet.
- **All proposed structures meet setback requirements.**
- Section 6.19 states, "The minimum dimension of the main body of the dwelling unit shall not be less than twenty-two (22) feet. **No dwelling units are planned for the property.**
- Section 6.9 of the Zoning Ordinance requires a 10' separation between the principal structure and all accessory structures as well as between all accessory structures. **All proposed structures are currently proposed to be greater than 10 feet from all other above-ground structures. The two proposed holding tank will likely be installed underground and will not be impacted by this requirement. Compliance with district requirements can be assured by requiring that a Zoning Permit Application be filed prior to any construction.**
- Section 6.31(A) of the Zoning Ordinance states:
 On a corner lot, nothing shall be erected, placed, planted or allowed to grow in such a manner as to impede vision between a height of two and one-half (2-1/2) feet and ten (10) feet above the center line grades of the area described as follows:
 That area bounded by the street right-of-way lines of a corner lot and a straight line joining points on said right-of-way lines twenty-five (25) feet from the point of intersection of said right-of-way lines. **There is a conflict in requirements between this provision and the fence wall requirements for a travel trailer park in the ordinance. Safety of traffic is a more serious concern, particularly with the high traffic speeds of 210th Street (County Road B-43). A chain link fence that can be seen through is probably the best balance between these conflicting rules. Requiring some plantings along the right-of-way lines of Killdeer Avenue and 210th Street away from the intersection and the road culvert running under 210th Street will help screen the special use.**

STATUTORY REQUIREMENTS:

Additional requirements under Iowa Code pertain to the Special Use applied for:

A storm water discharge permit will be required from the Iowa Department of Natural Resources if more than an acre of land is disturbed for the development of the travel trailer park.

Any water system serving the campground will likely be considered a public water system and will require regular testing according to DNR requirements. Wastewater disposal is under the jurisdiction of the Cerro Gordo County Department of Public Health. The method of wastewater disposal should be subject to approval by the Department of Public Health.

Approval by the Board of Supervisors and, if it meets certain thresholds, by property owners within Drainage District 45 for Dewey to replace public drainage structures. Application is done through Cerro Gordo County Auditor's Office.

Approval by the County Engineer is required for any vegetation that may obstruct views for traffic 210th Street (County Road B-43).

STAFF ANALYSIS AND RECOMMENDED ACTION:

Dewey's proposal meets most of the minimum requirements of Section 20.2(Q) of the Zoning Ordinance which sets minimum performance standards for travel trailer parks. Dewey is requesting a few variances as a result. I am comfortable recommending approval for most of these except a variance to the front yard setback requirement for the park, as I do not see a compelling reason to grant the variance. At a minimum, Lot 13, as shown on the site plan, should be moved to at least 25 feet from the right-of-way line of Killdeer Avenue.

There are still questions about the placement of electric utilities, dumpsters, vehicular directional signs, the well, and the method of wastewater disposal. The primary impacts will be traffic, some noise, and smoke from recreational and cooking fires. The primary corollary of increased traffic will be large vehicles turning off and onto 210th Street (County Road B-43), which should require the placement of warning signs for turning traffic along the road at the expense of Dewey.

Additionally, the replacement of the public drainage tile is likely to be a major improvement for drainage and the prospects for crop growth on nearby farm fields. Dewey, however, must be able to show that this is an actual improvement and receive the necessary approvals from the Board of Supervisors.

I am comfortable recommending approval of the Special Use Permit subject to the conditions stated below.

RECOMMENDED CONDITIONS TO BE MET IF POSITIVE VOTE BY BOARD OF ADJUSTMENT:

Note: In granting a Special Use Permit, the Board of Adjustment may attach conditions which it finds are necessary to carry out the purpose of the Zoning Ordinance, in conformance with what is provided in Article 20 of the Zoning Ordinance, and where reasonable and necessary may increase the required lot or yard, control the location and number of vehicular access points to the property, limit the number of signs, limit coverage or height of buildings because of obstruction to view and reduction of light and air to adjacent property, and require screening and landscaping to reduce noise and glare and maintain the property in character in keeping with the surrounding area. Special uses shall ordinarily comply with the standards of the district concerned for principal uses which are permitted therein, except as modified by the Board of Adjustment in granting a special use permit.

The following conditions are recommended:

1. This Special Use Permit may be reviewed at any time in the future upon the request of the applicants or a majority of the Board of Adjustment members.
2. The provisions and/or regulations shall be minimum requirements and wherever the requirements of any other lawfully adopted rules, regulations or ordinances are at a variance, the most restrictive shall govern.
3. It is contemplated that from time to time during the operation of a travel trailer park, that conditions may arise which are not covered by the terms of this permit and which cannot be anticipated. In the event such conditions do arise, the Board of Adjustment of Cerro Gordo County, Iowa, may impose additional regulations to meet any new conditions. In addition, if said use should, at any time, be operated in any manner which violates the rules and regulations of any federal or state regulatory agency, then the Board of Adjustment may impose such other conditions so as to insure compliance with such rules and regulations.
4. This permit will be subject to revocation for operator's failure to comply with the provisions as herein set forth or such other provisions as may, from time to time, be imposed by the Board of Adjustment of Cerro Gordo County, Iowa, under the terms of this permit.

5. County representatives shall have the right to enter the premises at any time upon notification to the permit holder for the purposes of enforcing the provisions of this Special Use Permit.
6. This Special Use Permit shall be applicable to William Dewey, successors, and assigns as well as any future owner of the travel trailer park.
7. Any other necessary permits or licenses required by federal, state, and local agencies including, but not limited to, the Iowa Department of Natural Resources shall be obtained by the applicant and current copies placed on file with the Zoning Administrator.
8. The requirement for an asphaltic concrete surface on interior drives contained in Section 20.2(Q)(1)(f) is waived. A variance is hereby granted for all interior drives to be 20 feet in width with curve widths and one-way traffic patterns as shown on the site plan. Signs shall be posted directing traffic as necessary throughout the property.
9. One or more trash receptacles with a closing lid, impermeable to birds or rodents, shall be provided in a location(s) convenient to users. At no time shall trash be visible above or outside of the receptacle. Trash shall be removed on a regular basis.
10. Use of the travel trailer park shall be limited to the period between April 15 and November 15 of each year. The ongoing storage of unoccupied mobile homes, travel trailers, campers, converted buses, motor homes, tent trailers, or similar devices is prohibited except for the storage of the applicant's personally owned travel trailer.
11. A Zoning Permit shall be required prior to the construction of any permanent structure on the property.
12. Potable water shall be provided in a method approved by the Iowa Department of Natural Resources.
13. The applicant shall file a final site plan within six months of final approval, showing the design and location of the electrical system and hookups, security lighting, dumpsters, vehicular directional signs, vegetative plantings, water distribution system, and wastewater handling. Said site plan shall be consistent with the findings and modifications as approved by the Board of Adjustment and the conditions of this Special Use Permit.
14. Security lights shall be installed at the entrance to the site and elsewhere in the travel trailer park to provide safe vehicular travel within the park.
15. The applicant shall receive all required permits from the Cerro Gordo County Department of Public Health for all well and wastewater facilities. The applicant shall remove wastewater from the site only by a method approved by the Cerro Gordo County Department of Public Health. Bathroom facilities shall also be provided for occupants of the travel trailer park.
16. All recreational vehicles shall be located on the site for less than 180 consecutive days and be fully licensed and ready for highway use at all times as defined by the Zoning Ordinance. Permanently attached additions to any travel trailer or recreational vehicle shall be prohibited.
17. The repair or replacement of any public drainage structures shall be approved by the Cerro Gordo County Board of Supervisors prior to beginning. The request for said repair or replacement shall be made through the Cerro Gordo County Auditor's Office, consistent with the rules and procedures of Iowa Code Chapter 468 in regard to public drainage districts. All of said repair or replacement of any public drainage structures shall be at the expense of the applicant.
18. At no time shall the applicant obstruct the water flow, or cause to take additional water flow, to the road culvert running under 210th Street (County Road B-43).
19. The applicant shall work with the County Engineer to have traffic signs installed warning driver's traversing 210th Street (County Road B-43) of turning traffic of large vehicles. The costs for the signs and installation of said signs shall be at the applicant's expense.
20. The use of all community facilities, including the shower facilities, game room, laundry, and any future facilities, shall be restricted to occupants of the travel trailer park only.
21. At no time shall vegetation be installed or planted nor any structure constructed or placed within the vision clearance area as described in Article 6.31(A) of the Zoning Ordinance at the intersection of 210th Street (County Road B-43) and Killdeer Avenue. An 8-foot tall chain link fence may be constructed as shown on the site plan with the issuance of a Zoning Permit so that traffic may clearly see through said vision clearance area. Said fence shall be constructed entirely on the applicant's property.
22. A south side yard setback variance is hereby granted for Lots 2-4 and 14-16 to be no closer than 30 feet.
23. A front yard setback variance, specifically for the travel trailer spaces as required in Article 20.2(Q)(2)(d) of the Zoning Ordinance, is hereby granted 7, 13, and 14 as shown on the site plan.
24. Parking for one additional vehicle is permitted within Lots 1-6, 9-12, 15, and 16. At no time shall any vehicle be permitted to park on the interior drives designed to traverse around the park. All other vehicles, not including travel trailers using designated lots, shall park in an alternative location designated for such purpose.
25. The applicant shall install a continuous vegetative plantings of evergreen or coniferous types along the right-of-way lines of 210th Street (County Road B-43) and Killdeer Avenue behind the chain link fence as shown on the

site plan to screen the park. However, said plantings shall not be installed within 25 feet of the intersection of 210th Street and Killdeer Avenue or the culvert running under 210th Street. Said plantings shall be a minimum of 6 feet in height at maturity and not overhang any public right-of-way.

26. The Zoning Administrator shall review this permit two years after the date of final approval by the Board of Adjustment. Any non-compliance shall be brought to the attention of the Board of Adjustment.

QUESTIONS & COMMENTS:

Proposed motion on application: To adopt the staff report as the Board's findings and to grant the application, subject to the conditions recommended by staff and as modified by the Board of Adjustment, for the establishment of a travel trailer park, and further, that the grant of the application be made effective immediately and on the condition that William Dewey shall perform all operations under the application under the specific direction of the Cerro Gordo County Zoning Administrator, consistent with the proposed conditions and recommendations approved by the Board of Adjustment, until such time as a formal resolution is drafted and adopted by the Board of Adjustment, not to exceed 60 days.

Proposed motion for denial of application: To adopt the staff report as the Board's findings and to deny the application for the reasons stated in the staff report as well as for the following reasons: **[STATE ADDITIONAL REASONS FOR DENIAL, IF ANY]**. Said reasons for denial shall be stated in the official transcript and minutes of the Board of Adjustment, and shall be made in writing to the applicant in letter form by the Board's secretary.

Prepared by:

John Robbins
Planning and Zoning Administrator
Final Draft Date – March 15, 2019

APPLICATION/APPEAL FORM

[For Completion by All Applicants]

Date MARCH 3, 2019

TO: ZONING BOARD OF ADJUSTMENT
CERRO GORDO COUNTY, IOWA

I (WE), WILLIAM DEWEY
(NAME)

OF P.O. BOX 102 ROCKWELL, IA 50469
(MAILING ADDRESS)

respectfully request that a determination be made by the Board of Adjustment on this Application/Appeal based on the letter written by the Zoning Administrator dated _____ for the reason that it was a matter which, in his/her opinion, should come before the Board of Adjustment.

This Application/Appeal is: (Please Check One)

- A Variance to a Zoning District requirement where there are unusual conditions or circumstances which cause a hardship when the provisions of Zoning are strictly applied.
- A Special Use listed in Article 20.2 of the Zoning Ordinance upon which the Board is required to act under the Ordinance.
- An Appeal where it is alleged there is error in any order, requirement, decision or determination made by the Zoning Administrator in the enforcement of the Zoning Ordinance.

The property affected is located in Section 11 of MOUNT VERNON Township.

The property affected is zoned AG 1 and AG 2 according to the Cerro Gordo County Zoning District Maps. Legal description of the property is: _____

I am the Owner Contract Purchaser Other (Explain) _____
_____ of the property affected.

Describe what you are proposing to do on the property affected.
Construct a commercial 16 site campground
RV park. Detailed site plans provided.

I (We) grant permission to the Planning & Zoning staff and Board of Adjustment members to enter onto the above described property for purposes of review.

I (We) further state that if this request is granted, I (We) will proceed with the actual construction in accordance with the purposes herein stated and any conditions and/or requirements the Board of Adjustment may stipulate.

Signature of Applicant 

OFFICE USE ONLY

Date Filed _____ Case Number _____

Date Set for Hearing _____ Fee Paid _____

Application/Appeal was Granted Denied Tabled

**Case No. 19-25
William Dewey (11091 210th Street)**

Figure 1

Looking southwesterly from just west of the existing utility building



March 8, 2019, J. Robbins

Figure 2

Looking southerly from just west of the existing utility building



March 8, 2019, J. Robbins

Figure 3

Looking south from 210th Street at the currently cultivated west half of the site



March 8, 2019, J. Robbins

Figure 4

Looking at the existing utility building



March 8, 2019, J. Robbins

Figure 5
Looking at the existing wellhouse



March 8, 2019, J. Robbins

Figure 6
Looking at the northwest corner of the site from 210th Street



March 8, 2019, J. Robbins

Figure 7

Looking at the location of the 3 pull-through spaces and community building



March 8, 2019, J. Robbins

Figure 8

Looking at the proposed location of Dewey's personal travel-trailer space and office building



March 8, 2019, J. Robbins

Figure 9

Looking at the residence to the northwest of the site



March 8, 2019, J. Robbins

Figure 10

Looking west along 210th Street from the east driveway



March 8, 2019, J. Robbins

Figure 11

Looking along the right-of-way line of Killdeer Avenue



March 8, 2019, J. Robbins

Figure 12

Looking toward the right-of-way of 210th Street (culvert buried in snow)



March 8, 2019, J. Robbins

Figure 13

Looking at the proposed location of the leech field



March 8, 2019, J. Robbins

Figure 14

Looking toward the farmland to the south of the site



March 8, 2019, J. Robbins

CAMPGROUND PROPOSAL

Members of the board,

I, William Dewey, wish to present for your consideration, my plan for a commercial campground/RV park located at 11091 210th Street, Rockwell IA 50469. The location, (which I own), for this project is remote enough to pose essentially zero adverse effects to neighbors. Yet, it is in a convenient location for RVers to access while visiting Cerro Gordo County and all the county has to offer.

My campground is not a large park, (16 sites) but rather a niche park with a charm all it's own. I am an RV enthusiast, and have knowledge of the industry. I also own a motorcoach myself. Recently, as of 2017, the sales industry wide for RVs in the United States reached the fifty billion dollar mark. I have read in publications that there is a shortage of good campgrounds available in relation to the sheer number of RVs on the road. I am in hopes to alleviate, be it in a small way, some of that shortage.

My mission is to provide a quaint, appealing, peaceful, and of course, fun camping experience for those choosing to stay at my campground. I will have strict rules for campground etiquette. I also want to promote to my guests the many things to see and do in Cerro Gordo County.

One of the positive aspects of the campground will possibly be when Winnebago Industries in Forest City is at full capacity during the summer service load. I know at times their spaces are full of owners waiting for their service appointment, (many arrive days early), and the overflow have limited places to stay. For at least those coming from the south or east via I-35 or Avenue of Saints, I would be able to provide a place to stay until their service appointment date.

As I stated earlier, I want to promote the activities and locations around Cerro Gordo County. The over half century old Family Motorcoach Association is planning to feature my campground/RV park in their monthly magazine "Family RVing". I plan to direct them to several key places around Cerro Gordo County, which they will likely visit and include in the feature. They have told me that they get calls frequently from members, (I am a member also), asking for recommendations to RV parks. They are excited to come to Cerro Gordo County, and to have a member who owns/operates a camping destination. I am excited to have them visit! I also plan, if possible, to have an association with Good Sam, and Passport America, of which I am also an active RVing member. They provide promotion of campgrounds and discounts to members for those parks.

I have been active for over a year to meet or exceed the requirements of the zoning guidelines. I have supplied maps and for the site. There will be more information to follow at the time of the meeting March 26th. I have laid out every aspect of the site grade and infrastructure. I will outline everything in person describing structures, electrical, plumbing, etc. (in detail). I have a pond as part of the layout. I will show how this pond, and upgrading of surrounding tile, will take great stress off of surrounding farm fields....of which have had slow drainage issues for many years. I very well could make those issues nearly nonexistent. I am doing this, (though I do want a pond), as a neighbor with no cost to the farmers surrounding me.

I will respectfully ask for leniency on a few "minimums" in site footages, based on my limited acreage, and the previously mentioned essentially zero percentage of imposing on neighboring properties and owners. I will explain in more detail verbally on March 26th.

I have involved other professionals in their respective trades. I plan to have them with me in attendance on March 26th to help answer any and all questions the board may have.

In closing,

I have a vision to be very active as a productive positive business in Cerro Gordo County. Once the park is up and running and well established.....it is my wish that area businesses, RV park patrons, city and county officials, and citizens of the area are all proud of it's existence.

Thank you all for your time and consideration. I look forward to March 26th.

Sincerely,

A handwritten signature in black ink, appearing to be "Walter A. [unclear]", written in a cursive style.

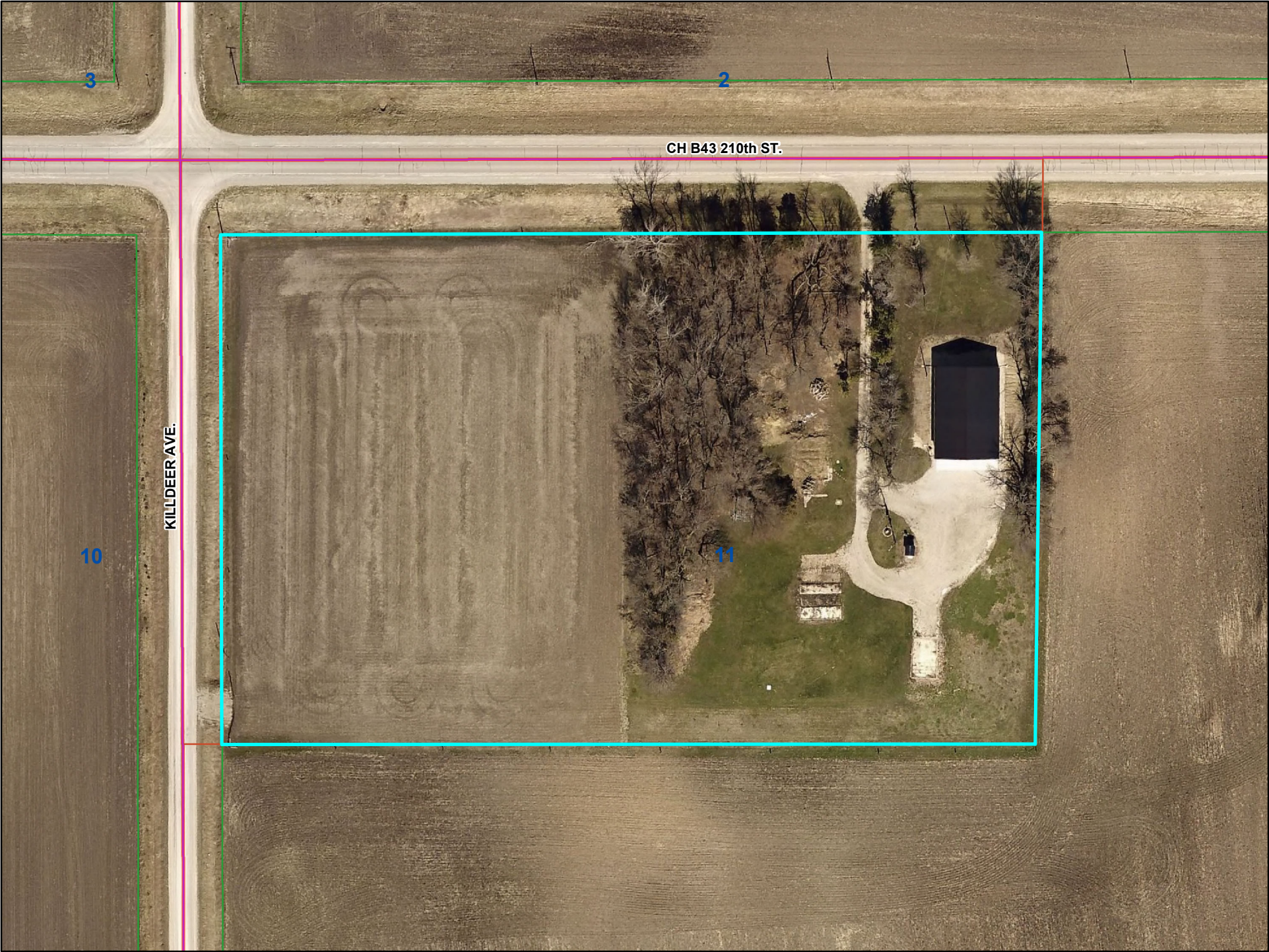

CH B43 210th ST.

KILLDEER AVE.

3

2

10

11

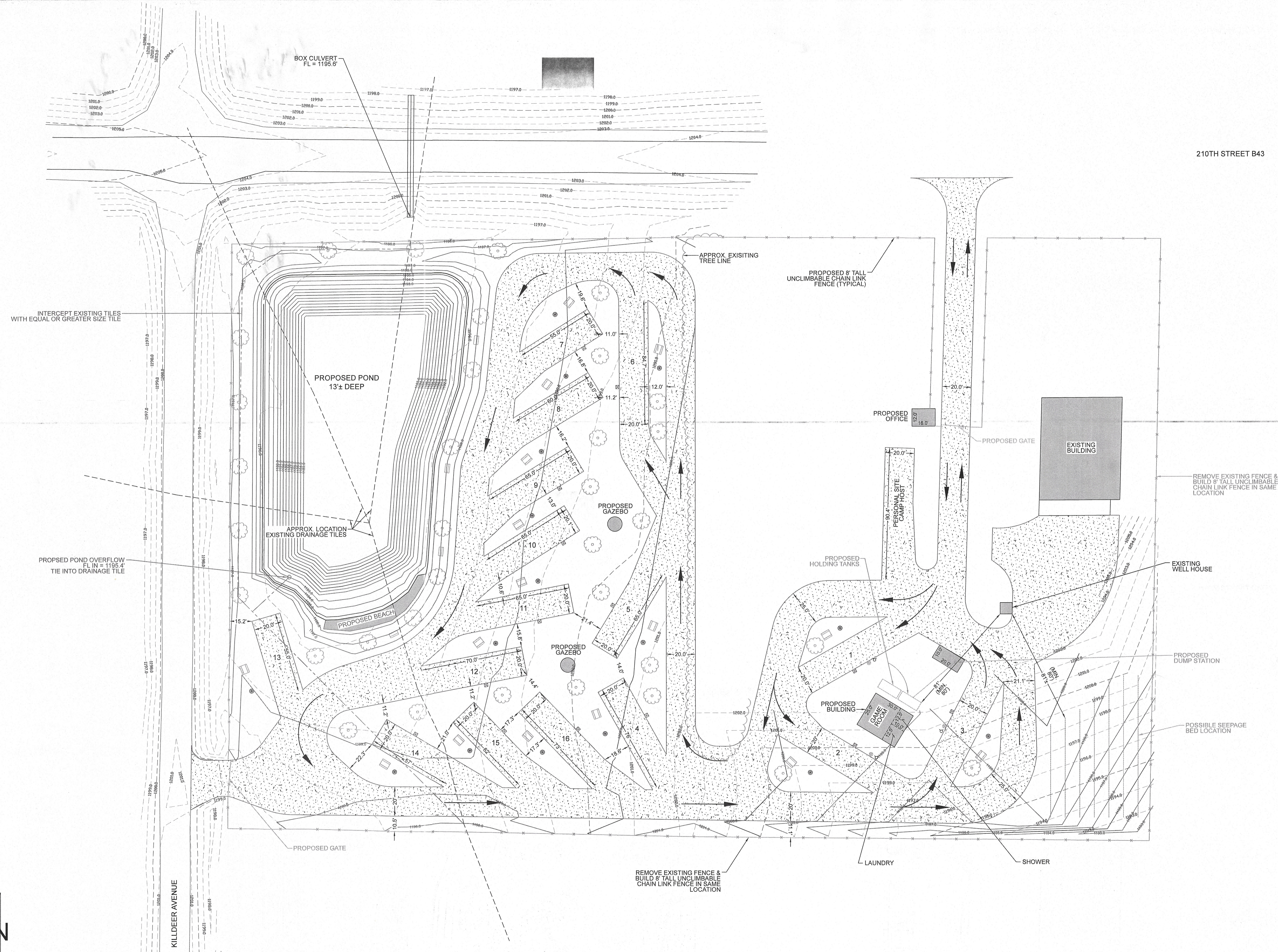

EARTHWORK
 9000± C.Y. CUT
 4770± C.Y. FILL
 (1.3 SHRINK FACTOR)
 1560± C.Y. NET CUT
 ABOVE VOLUMES DO NOT
 INCLUDE STRIPING AND
 STOCKPILING 5800 C.Y. OF
 BLACK DIRT, APPROX. THE
 TOP 6"

- LEGEND**
- EXISTING CONTOUR
 - PROPOSED CONTOUR
 - ▨ PROPOSED ROCK DRIVE
 - 4 PROPOSED SITE
 - ⊙ PROPOSED TREE/BUSH
 - ▭ PROPOSED PICNIC TABLE
 - ⊙ PROPOSED FIRE PIT
 - ⊗ PROPOSED ELECTRIC PEDESTAL
 - ⊕ PROPOSED SEWER CONNECTION
 - ⊕ PROPOSED WATER HYDRANT
 - ▭ PROPOSED BENCH

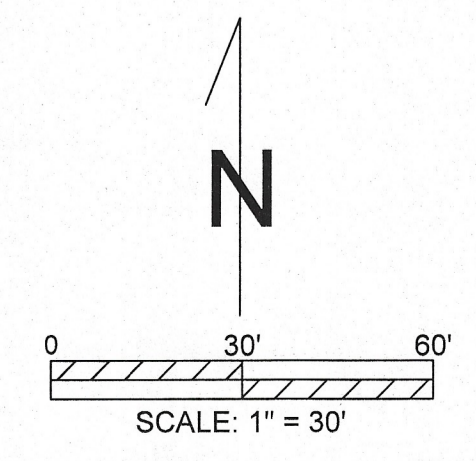

DRAWN BY: TCH	APPROVED BY:	REVISIONS:
DATE: 3/5/2019	PROJECT #:	
FIELD BOOK: X	DWG. NAME:	

HEARTLAND
 A SPECIALTY, INC.
 2601 S. FEDERAL AVE.
 MASON CITY, IOWA 50401
 Phone: 641-424-1733
 Fax: 641-424-0334

PROJECT
 Dewey Campground

SHEET NAME
 Proposed Site

SHEET NO.
 1 of 1

210TH STREET B43

BOX CULVERT
FL = 1195.6

INTERCEPT EXISTING TILES
WITH EQUAL OR GREATER SIZE TILE

PROPOSED POND
13± DEEP

APPROX. LOCATION
EXISTING DRAINAGE TILES

PROPOSED POND OVERFLOW
FL IN = 1195.4
TIE INTO DRAINAGE TILE

APPROX. EXISTING
TREE LINE

PROPOSED 8' TALL
UNCLIMBABLE CHAIN LINK
FENCE (TYPICAL)

PROPOSED OFFICE

PROPOSED GATE

EXISTING BUILDING

REMOVE EXISTING FENCE &
BUILD 8' TALL UNCLIMBABLE
CHAIN LINK FENCE IN SAME
LOCATION

EXISTING WELL HOUSE

PROPOSED DUMP STATION

POSSIBLE SEEPAGE
BED LOCATION

REMOVE EXISTING FENCE &
BUILD 8' TALL UNCLIMBABLE
CHAIN LINK FENCE IN SAME
LOCATION

LAUNDRY

SHOWER

EARTHWORK

9000± C.Y. CUT
4770± C.Y. FILL
(1.3 SHRINK FACTOR)
1560± C.Y. NET CUT
ABOVE VOLUMES DO NOT
INCLUDE STRIPING AND
STOCKPILING 5000 C.Y. OF
BLACK DIRT, APPROX. THE
TOP 6"

LEGEND

- EXISTING CONTOUR
- PROPOSED CONTOUR
- PROPOSED ROCK DRIVE
- PROPOSED SITE
- PROPOSED TREE/BUSH
- PROPOSED PICNIC TABLE
- PROPOSED FIRE PIT
- PROPOSED ELECTRIC PEDESTAL
- PROPOSED SEWER CONNECTION
- PROPOSED WATER HYDRANT
- PROPOSED BENCH

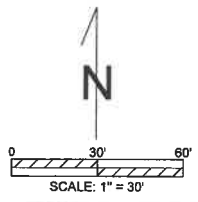

KILLDEER AVENUE

DRAWN BY: TCH	APPROVED BY:	REVISIONS:		2501 S. FEDERAL AVE MASON CITY, IOWA 50401 Phone: 641-424-1733 Fax: 641-424-0334	PROJECT	SHEET NAME	SHEET NO.
DATE: 3/5/2019	PROJECT #:				Dewey Campground	Proposed Site	1 of 1
FIELD BOOK X	DWG. NAME:						